



(11) **EP 3 342 341 B1**

(12) **EUROPEAN PATENT SPECIFICATION**

(45) Date of publication and mention of the grant of the patent:
18.12.2019 Bulletin 2019/51

(51) Int Cl.:
A61B 5/22 (2006.01) **A61B 5/103** (2006.01)
A61B 5/00 (2006.01) **G01G 19/50** (2006.01)
G01L 1/16 (2006.01) **G01L 5/00** (2006.01)

(21) Application number: **15902503.0**

(86) International application number:
PCT/CN2015/088390

(22) Date of filing: **28.08.2015**

(87) International publication number:
WO 2017/035696 (09.03.2017 Gazette 2017/10)

(54) **MULTI-AXIS LOAD BEARING AND GRAVITY CENTER MEASURING DEVICE**

MEHRACHSIGE VORRICHTUNG ZUR LASTTRAGE- UND SCHWERPUNKTZENTRUMSMESSUNG
DISPOSITIF DE MESURE DU CENTRE DE GRAVITÉ ET DE SUPPORT DE CHARGES À AXES MULTIPLES

(84) Designated Contracting States:
AL AT BE BG CH CY CZ DE DK EE ES FI FR GB GR HR HU IE IS IT LI LT LU LV MC MK MT NL NO PL PT RO RS SE SI SK SM TR

- **LIAW, Lih-Jiun**
Kaohsiung 80708 (TW)
- **CHENG, Jhen-Cyun**
Kaohsiung 80708 (TW)

(43) Date of publication of application:
04.07.2018 Bulletin 2018/27

(74) Representative: **Schaumburg und Partner**
Patentanwälte mbB
Postfach 86 07 48
81634 München (DE)

(73) Proprietor: **Kaohsiung Medical University**
80708 Kaohsiung City (TW)

(72) Inventors:

- **GUO, Lan-Yuen**
Kaohsiung 80708 (TW)
- **YEN, Chen-Wen**
Kaohsiung 80708 (TW)

(56) References cited:
WO-A1-2006/075941 **CN-A- 101 949 752**
CN-A- 104 083 175 **JP-A- 2001 146 830**
TW-A- 201 119 627 **TW-U- M 404 973**

EP 3 342 341 B1

Note: Within nine months of the publication of the mention of the grant of the European patent in the European Patent Bulletin, any person may give notice to the European Patent Office of opposition to that patent, in accordance with the Implementing Regulations. Notice of opposition shall not be deemed to have been filed until the opposition fee has been paid. (Art. 99(1) European Patent Convention).

Description

CROSS REFERENCE

[0001] This application is the national phase of International Application No. PCT/CN2015/088390, filed on August 28, 2015.

FIELD OF THE INVENTION

[0002] The invention relates to a multi-axis measurement device for loading force and center of gravity. Specifically, the invention uses linear guideways and piezoelectric pressure sensors to substitute conventional high-priced measuring instruments that measure the ground reaction forces generated by a body standing on or moving across them.

BACKGROUND OF THE INVENTION

[0003] In modern times the rapid pace of life, high-pressure work, and irregular meal patterns adversely affect our bodies. Hence, health examinations, such as blood tests, eye examinations, and balance evaluations, become particularly important. Health examinations can also provide warnings when there are signs detected from our bodies which promotes early treatment and improved the effectiveness of health maintenance.

[0004] In the past, balance scale or functional tests, such as Berg Balance Scale and Timed Up and Go Test, were commonly used in clinics to determine a patient's balance ability. The Berg Balance Scale was developed by Katherine Berg and the colleagues early in 1989 to evaluate the functional static and dynamic balance abilities. In 1992 and 1995, the Berg Balance Scale was increasingly applied for the elderly and acute stroke patients. Research results showed excellent within-rater, between-rater reliabilities (both ICCs were 0.98) and internal consistency (Cronbach's $\alpha = 0.96$). In 1996, Bogle and other researchers used this balance scale to assess balance status and fall risk among elder people. They found that those who scored less than 45 points had a higher chance of falls compared to those who scored more than 45 points. Although it didn't mean that the lower a subject scores the higher chance of fall the subject has, it still provides a cut-off point (cut-off score) to predict the possibility of falls in clinical practice. The Timed Up and Go Test was first used by Mathias and the colleagues in 1986 to study 40 elder people exhibiting balance dysfunctions. They observed the subject rising from a chair with handles, walking three meters, turning around, walking back to the chair, and sitting down. This test integrates a series of daily activities such as from sitting to standing, walking, turning, and from standing to sitting. Although this test is a fast and useful balance function test, the scoring procedure is rough and balance function is scored on a five-point scale. Only extreme scores of 1 and 5 are scored with a more consistent consensus, while

intermediate scores of 2 to 4 are less objective.

[0005] Due to the development of technology and medicine, members of society are aging in recent years. Some manual health examinations, such as eye examinations and balance evaluations, have been replaced by instruments. For instance, due to the invention of the electronic force plate, the measurement of position of center of gravity becomes more accurate. The principle of the force plate is to use uniaxial piezoelectric pressure sensors or triaxial piezoelectric pressure sensors to detect pressure signals from different directions, and convert the signals into the distribution of the position of center of gravity.

[0006] Taiwan Patent No. M404973 "THE NEW THREE-DIMENSIONAL FORCE PLATE" discloses a three-dimensional center-of-gravity position measuring force plate, including a balance board, four columns, a base plate, and four groups of pressure sensing modules that are composed of different specifications of pressure sensors, to achieve accuracy of measurement. The columns are disposed on the base plate and the groups of pressure sensors orthogonally contact the top of the columns. When an object is placed on the balance board, the force information from the X-axis, the Y-axis and the Z-axis can be collected and calculated to obtain the object's center-of-gravity position. Another force plate is known from WO2006/075941

[0007] The three-dimensional center-of-gravity position measuring force plate as mentioned above features the modular design of pressure sensors. When an object is placed on the force plate, the force plate can capture the information of the object's center-of-gravity position. Said force plate can be applied to game machines, medical facilities, exercise measurements, and education equipments, etc.

[0008] However, the center-of-gravity measuring force plates on the market mostly use uniaxial or triaxial piezoelectric sensing elements to measure the position of center of gravity of an object. The piezoelectric sensing elements are placed in the four corners of the center-of-gravity measuring force plates, respectively, or placed at four beam columns of the center-of-gravity measuring force plates, respectively. The high-priced three-dimensional pressure sensor is currently imported. In a business point of view, it is therefore inconvenient to repair or replace the broken part once a sensor is damaged. Moreover, it is not suitable for home use and consequently the patient has to go to a hospital for examination.

[0009] Therefore, it is a common goal for businesses and developers to overcome the problems of a high-cost of electric force plate, inconvenient repair, and residential examination difficulties.

BRIEF SUMMARY OF THE INVENTION

[0010] The objective of the present invention aims at improving the drawbacks of available conventional center-of-gravity measuring force plates. The inventor is ac-

tively engaged in the development through continuous testing and efforts, to finally successfully develop the present invention.

[0011] In order to achieve the above and other objectives, the present invention comprises: a first loading plate, and further comprises: a first slidable element, one end of which is connected to the first loading plate and moves along a first direction; and a first piezoelectric sensing element, one end of which is connected to the first loading plate. A second loading plate further comprises a second slidable element, one end of which is connected to the second loading plate and moves along a second direction; and a second piezoelectric sensing element, one end of which is connected to the second loading plate. A connecting plate is located between the first loading plate and the second loading plate, wherein the connecting plate respectively connects to the first slidable element, the first piezoelectric sensing element, the second slidable element, and the second piezoelectric sensing element. A plurality of third piezoelectric sensing elements are connected to the first loading plate; wherein the first piezoelectric sensing element measures the changes in pressure of the first direction, the second piezoelectric sensing element measures the changes in pressure of the second direction, and the third piezoelectric sensing element measures the changes in pressure of a third direction.

[0012] An embodiment of the present invention further comprises a signal acquisition device used for capturing changes in pressure and converting it into a digital signal, and is electrically connected to the first piezoelectric sensing element, the second piezoelectric sensing element, and the third piezoelectric sensing element. A computational unit used for calculating the digital signal and generating a calculation result, is electrically connected to the signal acquisition device. A display unit used for displaying the calculation result is electrically connected to the computational unit.

[0013] An embodiment of the present invention further comprises a horizontal adjustment unit used for adjusting the horizon.

[0014] An embodiment of the present invention further comprises a weight measurement unit used for measuring weight.

[0015] An embodiment of the present invention further comprises wherein the first direction, the second direction, and the third direction are perpendicular to each other (are perpendicular mutually).

[0016] An embodiment of the present invention further comprises wherein the first slidable element is one of a linear guideway, a ball bearing guideway, a shaft type guideway, or a bearing.

[0017] An embodiment of the present invention further comprises wherein the second slidable element is one of a linear guideway, a ball bearing guideway, a shaft type guideway, or a bearing.

[0018] An embodiment of the present invention further comprises wherein the first piezoelectric sensing ele-

ment is one of a strain gauge, a load cell, a piezoelectric material, an accelerometer, or any combination thereof.

[0019] An embodiment of the present invention further comprises wherein the second piezoelectric sensing element is one of a strain gauge, a load cell, a piezoelectric material, an accelerometer, or any combination thereof.

[0020] An embodiment of the present invention further comprises wherein the third piezoelectric sensing element is one of a strain gauge, a load cell, a piezoelectric material, an accelerometer, or any combination thereof.

BRIEF DESCRIPTION OF THE DRAWINGS

[0021]

FIG. 1 is a perspective schematic view of an embodiment of the present invention;

FIG. 2 is a perspective exploded view of an embodiment of the present invention;

FIG. 3 is a side schematic view of an embodiment of the present invention;

FIG. 4 is another side schematic view of an embodiment of the present invention; and

FIG. 5 is a perspective schematic view of another embodiment of the present invention.

DETAILED DESCRIPTION OF THE EMBODIMENTS

[0022] In order to achieve the above objects, the following technical means and structures of the present invention are illustrated by drawings and described below. It should be noted that the described embodiments are illustrative. The claims limit the scope of the invention.

[0023] As shown in FIG. 1 and FIG. 2, an embodiment of the present invention is illustrated in a perspective schematic view and a perspective exploded view. The multi-axis measurement device for quantifying loading force and center of gravity 1 comprises:

a first loading plate 2, a second loading plate 3, a connecting plate 4, and a plurality of third piezoelectric sensing elements 5.

[0024] The first loading plate 2 can be a metal plate. The first loading plate 2 comprises: two first slidable elements (21a, 21b) and two first piezoelectric sensing elements 22.

[0025] One end of the two first slidable elements (21a, 21b) 21a is connected to the first loading plate 2, while the other end 21b is connected to a side of the connecting plate 4. When the first slidable elements (21a, 21b) encounter an external force toward a first direction (X-axis direction), the slidable elements (21a, 21b) move along the first direction. In one embodiment of the present invention, the first slidable elements (21a, 21b) are one of a linear guideway, a ball bearing guideway, a shaft type guideway, or a bearing. A user could choose guideways or bearings with different measurement accuracies depending on the user's needs.

[0026] One end of the first piezoelectric sensing ele-

ments 22 is connected to the first loading plate 2 via a connecting unit 221, while the other end is connected to the connecting plate 4 via another connecting unit 222, and the first piezoelectric sensing elements 22 are symmetrically disposed on the first loading plate 2.

[0027] When the first slidable elements (21a, 21b) encounter an external force and move along the first direction, the slidable elements (21a, 21b) simultaneously generate a force to press on the first piezoelectric sensing element 22. The first piezoelectric sensing element 22 learns the changes in pressure of the first direction while perceiving the force. Preferably, the first piezoelectric sensing element 22 is one of a strain gauge, a load cell, a piezoelectric material, an accelerometer, or any combination thereof.

[0028] The second loading plate 3 can be a metal plate. The second loading plate 3 comprises: two second slidable elements (31a, 31b) and two second piezoelectric sensing elements 32.

[0029] One end of the two second slidable elements (31a, 31b) 31a is connected to the second loading plate 3, while the other end 31b is connected to the other side of the connecting plate 4. When the second slidable elements (31a, 31b) encounter an external force toward a second direction (Y-axis direction), the slidable elements (31a, 31b) move along the second direction. In one embodiment of the present invention, the second slidable elements (31a, 31b) are one of a linear guideway, a ball bearing guideway, a shaft type guideway, or a bearing. A user could choose guideways or bearings with different measurement accuracies depending on the user's needs.

[0030] One end of the second piezoelectric sensing elements 32 is connected to the second loading plate 3 via a connecting unit 321, while the other end is connected to the connecting plate 4 via another connecting unit 322, and the second piezoelectric sensing elements 32 are symmetrically disposed on the second loading plate 3.

[0031] When the second slidable elements (31a, 31b) encounter an external force and move along the second direction, the slidable elements (21a, 21b) simultaneously generate a force to press on the second piezoelectric sensing element 32. The second piezoelectric sensing element 32 learns the changes in pressure while perceiving the force. Preferably, the second piezoelectric sensing element 32 is one of a strain gauge, a load cell, a piezoelectric material, an accelerometer, or any combination thereof.

[0032] As shown in FIG. 3 and FIG. 4, an embodiment of the present invention is illustrated in a side schematic view and another side schematic view. The connecting plate 4 is located between the first loading plate 2 and the second loading plate 3, wherein the connecting plate 4 can be a metal plate, and is slightly smaller than the first loading plate 2 and the second loading plate 3. The connecting plate 4 is respectively connected to the abovementioned first slidable elements (21a, 21b), the

first piezoelectric sensing element 22, the second slidable elements (31a, 31b), and the second piezoelectric sensing element 32.

[0033] The third piezoelectric sensing elements 5 are connected to the first loading plate 2 to measure the changes in pressure of a third direction (Z-axis direction). In the present embodiment, the quantity of the third piezoelectric sensor elements 5 is four, and the four third piezoelectric sensing elements 5 are respectively disposed on the four corners of the first loading plate 2 in order to measure the changes in pressure of the third direction more precisely, and therefore to calculate the position of the center of gravity of the measured object. Preferably, the third piezoelectric sensing elements 5 are a strain gauge, a load cell, a piezoelectric material, an accelerometer, or any combination thereof.

[0034] Through the above-mentioned configuration, when a subject acts on the multi-axis measurement device for quantifying loading force and center of gravity 1, the first slidable elements (21a, 21b) sense the actuating force of the first direction, and conduct to the first piezoelectric sensing element 22 via the connecting plate 4. In this way, the first piezoelectric sensing element 22 can acquire the changes in pressure of the first direction. The second slidable elements (31a, 31 b) sense the force of the second direction, and conduct to the second piezoelectric sensing element 32 via the connecting plate 4. In this way, the second piezoelectric sensing element 32 can acquire the changes in pressure of the second direction. The third piezoelectric sensing elements 5 sense the force of the third direction, which is generated by the subject due to gravity (i.e. weight), and the changes in pressure. Therefore, the multi-axis measurement device for quantifying loading force and center of gravity 1 can respectively measure the force signals of the first direction, the second direction, and the third direction.

[0035] In an embodiment of the present invention, the multi-axis measurement device for loading force and center of gravity 1 further comprises a weight measurement unit 51 for simultaneously measuring weight and balance performance. It is worth mentioning that the weight measurement unit 51 can be an independent mechanism or can be integrated into the third piezoelectric sensing elements 5 to carry out the measurement. Specific embodiment thereof is to sum the weights the third piezoelectric sensing elements 5 measured to obtain the subject's weight.

[0036] As shown in FIG. 5, an embodiment of the present invention is illustrated in a perspective schematic view. In an embodiment of the present invention, the multi-axis measurement device for loading force and center of gravity 1 further comprises a signal acquisition device 6, a computational unit 7, and a display unit 8.

[0037] The signal acquisition device 6 is electrically connected to the first piezoelectric sensing element 22, the second piezoelectric sensing element 32, and the third piezoelectric sensing elements 5, respectively, to capture and convert changes in pressure into a digital

signal.

[0038] The computational unit 7 is electrically connected to the signal acquisition device 6 to capture the digital signal and use the algorithm to assess balance capacities. The algorithm combines measurements of center of pressure (CoP) and Center of Mass (CoM) to provide an indicator of functional balance capacities..

[0039] The display unit 8 is electrically connected to the computational unit 7 to display the calculation result, real-time balance performance, and center of gravity information, etc.

[0040] In an embodiment of the present invention, the multi-axis measurement device for quantifying loading force and center of gravity 1 further comprises a horizontal adjustment unit 23, wherein the horizontal adjustment 23 is disposed on the first loading plate 2. The horizontal adjustment unit can be, but not limited to, a socket set bolt. The horizontal adjustment unit 23 can be used for adjusting the level of the whole device in order to adapt to uneven or tilting ground or surfaces.

[0041] To conclude, comparing the present invention which quantifies loading force and center of gravity, to the conventional technique, the present invention has the following advantages: The present invention of the multi-axis measurement device for quantifying loading force and center of gravity uses linear guideway and piezoelectric sensing elements as substitutes for high-priced electric three-dimensional sensors, so that the manufacturing cost is reduced, and home-based usage is more practical. The component parts of the multi-axis measurement device for quantifying loading force and center of gravity of the present invention are sold retail; hence the repair and maintenance are convenient and cost effective. The present invention of the multi-axis measurement device for quantifying loading force and center of gravity can use slidable elements with different measurement accuracies depending on the user's needs, hence has better adaptability and are easier to use, compared to the commercial triaxial force plate.

Claims

1. A multi-axis measurement device for loading force and center of gravity comprising:

a first loading plate, further comprising:

- a first slidable element, wherein one end of the first slidable element is connected to the first loading plate, and moves in a first direction; and
- a first piezoelectric pressure sensing element, wherein one end of the first piezoelectric pressure sensing element is connected to the first loading plate;

a second loading plate, further comprising:

a second slidable element, wherein one end of the second slidable element is connected to the second loading plate, and moves in a second direction; and

a second piezoelectric pressure sensing element, wherein one end of the second piezoelectric pressure sensing element is connected to the second loading plate;

a connecting plate, located between the first loading plate and the second loading plate, wherein the connecting plate is respectively connected to the first slidable element, the first piezoelectric pressure sensing element, the second slidable element, and the second piezoelectric pressure sensing element; and a plurality of third piezoelectric pressure sensing elements, connected to the first loading plate;

wherein the first piezoelectric pressure sensing element measures the changes in pressure of the first direction, the second piezoelectric pressure sensing element measures the changes in pressure of the second direction, and the third piezoelectric pressure sensing elements measure the changes in pressure of a third direction.

2. The multi-axis measurement device for loading force and center of gravity according to claim 1, further comprising:

- a signal acquisition device, electrically connected to the first piezoelectric pressure sensing element, the second piezoelectric sensor element, and the third piezoelectric pressure sensing elements, to capture changes in pressure and convert the changes in pressure into a digital signal;
- a computational unit, electrically connected to the signal acquisition device to calculate the digital signal and generate a calculation result; and
- a display unit, electrically connected to the computational unit to display the calculation result.

3. The multi-axis measurement device for loading force and center of gravity according to claim 1 or 2, further comprising a horizontal adjustment unit to adjust the horizon placement.

4. The multi-axis measurement device for loading force and center of gravity according to claim 1 or 2, further comprising a weight measurement unit to measure weight.

5. The multi-axis measurement device for loading force and center of gravity according to claim 1 or 2, wherein the first direction, the second direction, and the third direction are perpendicular mutually.

6. The multi-axis measurement device for loading force and center of gravity according to claim 1 or 2, wherein the first slidable element is one of a linear guideway, a ball bearing guideway, a shaft type guideway, or a bearing. 5
7. The multi-axis measurement device for loading force and center of gravity according to claim 1 or 2, wherein the second slidable element is one of a linear guideway, a ball bearing guideway, a shaft type guideway, or a bearing. 10
8. The multi-axis measurement device for loading force and center of gravity according to claim 1 or 2, wherein the first piezoelectric sensor element is one of a strain gauge, a load cell, a piezoelectric material, an accelerometer, or any combination thereof. 15
9. The multi-axis measurement device for loading force and center of gravity according to claim 1 or 2, wherein the second piezoelectric sensor element is one of a strain gauge, a load cell, a piezoelectric material, an accelerometer, or any combination thereof. 20
10. The multi-axis measurement device for loading force and center of gravity according to claim 1 or 2, wherein the third piezoelectric sensor element is one of a strain gauge, a load cell, a piezoelectric material, an accelerometer, or any combination thereof. 25

Patentansprüche

1. Mehrachsen-Belastungskraft- und -Schwerpunkt-Messvorrichtung, umfassend: 35
- eine erste Belastungsplatte, weiterhin umfassend:
- ein erstes gleitbewegliches Element, wobei ein Ende des ersten gleitbeweglichen Elements mit der ersten Belastungsplatte verbunden ist und sich in eine erste Richtung bewegt; und 40
- ein erstes piezoelektrisches Drucksensorelement, wobei ein Ende des ersten piezoelektrischen Drucksensorelements mit der ersten Belastungsplatte verbunden ist; 45
- und eine zweite Belastungsplatte, zusätzlich umfassend: 50
- ein zweites gleitbewegliches Element, wobei ein Ende des zweiten gleitbeweglichen Elements mit der zweiten Belastungsplatte verbunden ist und sich in eine zweite Richtung bewegt; und 55
- ein zweites piezoelektrisches Drucksensorelement, wobei ein Ende des zweiten piezoelektrischen Drucksensorelements mit der zweiten Belastungsplatte verbunden ist; 60

relement, wobei ein Ende des zweiten piezoelektrischen Drucksensorelements mit der zweiten Belastungsplatte verbunden ist;

eine Verbindungsplatte, welche zwischen der ersten Belastungsplatte und der zweiten Belastungsplatte angeordnet ist, wobei die Verbindungsplatte mit dem ersten gleitbeweglichen Element, dem ersten piezoelektrischen Drucksensorelement, dem zweiten gleitbeweglichen Element bzw. dem zweiten piezoelektrischen Drucksensorelement verbunden ist, und eine Vielzahl von dritten piezoelektrischen Drucksensorelementen, welche mit der ersten Belastungsplatte verbunden sind; wobei das erste piezoelektrische Drucksensorelement die Druckveränderungen in der ersten Richtung, das zweite piezoelektrische Drucksensorelement die Druckveränderungen in der zweiten Richtung und die dritten piezoelektrischen Drucksensorelemente die Druckveränderungen in einer dritten Richtung misst.

2. Mehrachsen-Belastungskraft- und -Schwerpunkt-Messvorrichtung nach Anspruch 1, zusätzlich umfassend 65
- eine Signalgewinnungsvorrichtung, die mit dem ersten piezoelektrischen Drucksensorelement, dem zweiten piezoelektrischen Drucksensorelement und den dritten piezoelektrischen Drucksensorelementen verbunden ist, um Druckveränderungen zu erfassen und die Druckveränderungen in ein digitales Signal umzuwandeln; 70
- eine Recheneinheit, die elektrisch mit der Signalgewinnungsvorrichtung verbunden ist, um das digitale Signal zu berechnen und ein Rechenergebnis zu erzeugen; und eine Anzeigeeinheit, die elektrisch mit der Recheneinheit verbunden ist, um das Rechenergebnis anzuzeigen. 75
3. Mehrachsen-Belastungskraft- und -Schwerpunkt-Messvorrichtung nach Anspruch 1 oder 2, zusätzlich umfassend eine Horizontaleinstelleinheit zur Einstellung der horizontalen Platzierung. 80
4. Mehrachsen-Belastungskraft- und -Schwerpunkt-Messvorrichtung nach Anspruch 1 oder 2, zusätzlich umfassend eine Gewichtsmesseinheit zum Messen von Gewicht. 85
5. Mehrachsen-Belastungskraft- und -Schwerpunkt-Messvorrichtung nach Anspruch 1 oder 2, wobei die erste Richtung, die zweite Richtung und die dritte Richtung jeweils zueinander senkrecht verlaufen. 90
6. Mehrachsen-Belastungskraft- und -Schwerpunkt-Messvorrichtung nach Anspruch 1 oder 2, wobei das 95

erste gleitbewegliche Element entweder eine lineare Führungsbahn, eine Kugellagerführungsbahn, eine Wellenführungsbahn oder ein Lager ist.

7. Mehrachsen-Belastungskraft- und -Schwerpunkt-Messvorrichtung nach Anspruch 1 oder 2, wobei das zweite gleitbewegliche Element entweder eine lineare Führungsbahn, eine Kugellagerführungsbahn, eine Wellenführungsbahn oder ein Lager ist. 5
8. Mehrachsen-Belastungskraft- und -Schwerpunkt-Messvorrichtung nach Anspruch 1 oder 2, wobei das erste piezoelektrische Sensorelement entweder ein Dehnungsmessstreifen, eine Kraftmessdose, ein piezoelektrisches Material, ein Beschleunigungsmesser oder eine Kombination hiervon ist. 10
9. Mehrachsen-Belastungskraft- und -Schwerpunkt-Messvorrichtung nach Anspruch 1 oder 2, wobei das zweite piezoelektrische Sensorelement entweder ein Dehnungsmessstreifen, eine Kraftmessdose, ein piezoelektrisches Material, ein Beschleunigungsmesser oder eine Kombination hiervon ist. 15
10. Mehrachsen-Belastungskraft- und -Schwerpunkt-Messvorrichtung nach Anspruch 1 oder 2, wobei das dritte piezoelektrische Sensorelement entweder ein Dehnungsmessstreifen, eine Kraftmessdose, ein piezoelektrisches Material, ein Beschleunigungsmesser oder eine Kombination hiervon ist. 20
- 25
- 30

Revendications

1. Dispositif de mesure de la charge et du centre de gravité à axes multiples comprenant : 35
- une première plaque de charge, comprenant en outre 40
- un premier élément coulissant, dans lequel une extrémité du premier élément coulissant est raccordée à la première plaque de charge et se déplace dans une première direction ; et un premier élément capteur de pression piézoélectrique, dans lequel une extrémité du premier élément de détection de pression piézoélectrique est raccordée à la première plaque de charge ; 45
- une deuxième plaque de charge, comprenant en outre 50
- un deuxième élément coulissant, dans lequel une extrémité du deuxième élément coulissant est raccordée à la deuxième plaque de charge et se déplace dans une deuxième direction ; et un deuxième élément de détection de pression piézoélectrique, dans lequel une extrémité du deuxième élément de détection de pression piézoélectrique est raccordée à la deuxième plaque de charge ; 55

une plaque de raccordement, située entre la première plaque de charge et la deuxième plaque de charge, dans lequel la plaque de raccordement est raccordée respectivement au premier élément coulissant, au premier élément de détection de pression piézoélectrique, au deuxième élément coulissant et au deuxième élément de détection de pression piézoélectrique ; et une pluralité de troisièmes éléments de détection de pression piézoélectriques, raccordés à la première plaque de charge ; dans lequel le premier élément de détection de pression piézoélectrique mesure les variations de pression de la première direction, le deuxième élément de détection de pression piézoélectrique mesure les variations de pression de la deuxième direction, et le troisième élément de détection de pression piézoélectrique mesure les variations de pression d'une troisième direction.

2. Dispositif de mesure de la charge et du centre de gravité à axes multiples selon la revendication 1, comprenant en outre :

un dispositif d'acquisition de signal, raccordé électriquement au premier élément de détection de pression piézoélectrique, au deuxième élément de détection piézoélectrique et au troisième élément de détection de pression piézoélectrique, pour capturer les variations de pression et convertir ces variations de pression en un signal numérique ;

une unité de calcul, raccordée électriquement au dispositif d'acquisition de signaux pour calculer le signal numérique et générer un résultat de calcul ; et

une unité d'affichage, raccordée électriquement à l'unité de calcul pour afficher le résultat du calcul.

3. Dispositif de mesure de la charge et du centre de gravité à axes multiples selon la revendication 1 ou 2, comprenant en outre une unité de réglage horizontal pour régler la position de l'horizon.
4. Dispositif de mesure de la charge et du centre de gravité à axes multiples selon la revendication 1 ou 2, comprenant en outre une unité de mesure de poids pour mesurer le poids.
5. Dispositif de mesure de la charge et du centre de gravité à axes multiples selon la revendication 1 ou 2, dans lequel la première direction, la deuxième direction et la troisième direction sont perpendiculaires entre elles.
6. Dispositif de mesure de la charge et du centre de

gravité à axes multiples selon la revendication 1 ou 2, dans lequel le premier élément coulissant est l'un parmi un guidage linéaire, un guidage à roulement à billes, un guidage du type à arbre ou un palier.

5

7. Dispositif de mesure de la charge et du centre de gravité à axes multiples selon la revendication 1 ou 2, dans lequel le deuxième élément coulissant est l'un parmi un guidage linéaire, un guidage à roulement à billes, un guidage du type arbre ou un palier. 10
8. Dispositif de mesure de la charge et du centre de gravité à axes multiples selon la revendication 1 ou 2, dans lequel le premier élément de capteur piézoélectrique est un élément parmi une jauge de contrainte, une cellule de charge, un matériau piézoélectrique, un accéléromètre, ou toute combinaison de ceux-ci. 15
9. Dispositif de mesure de la charge et du centre de gravité à axes multiples selon la revendication 1 ou 2, dans lequel le deuxième élément de capteur piézoélectrique est un élément parmi une jauge de contrainte, une cellule de charge, un matériau piézoélectrique, un accéléromètre ou toute combinaison de ceux-ci. 20
25
10. Dispositif de mesure de la charge et du centre de gravité à axes multiples selon la revendication 1 ou 2, dans lequel le troisième élément de capteur piézoélectrique est un élément parmi une jauge de contrainte, une cellule de charge, un matériau piézoélectrique, un accéléromètre ou toute combinaison de ceux-ci. 30
35

40

45

50

55

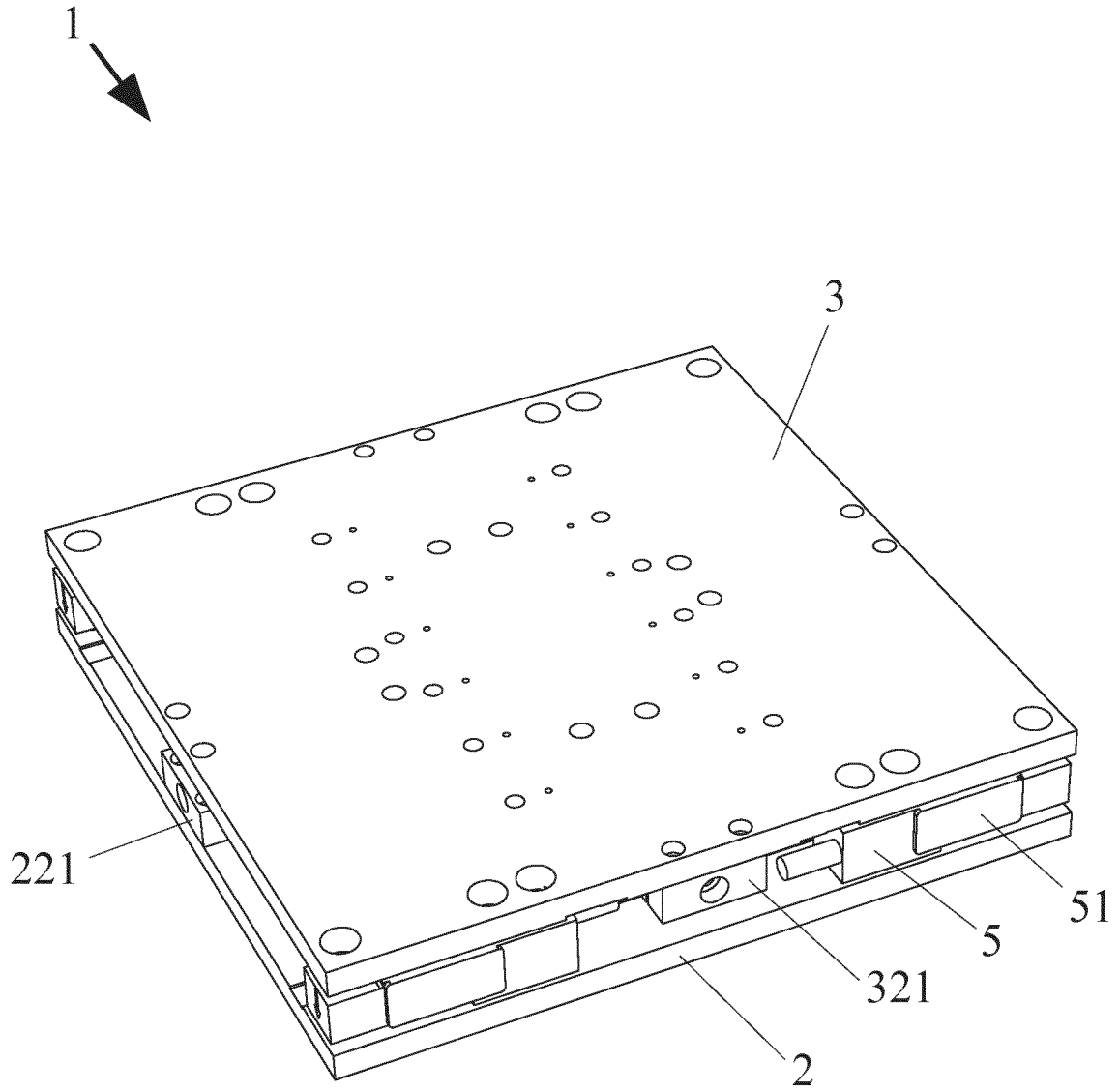

FIG. 1

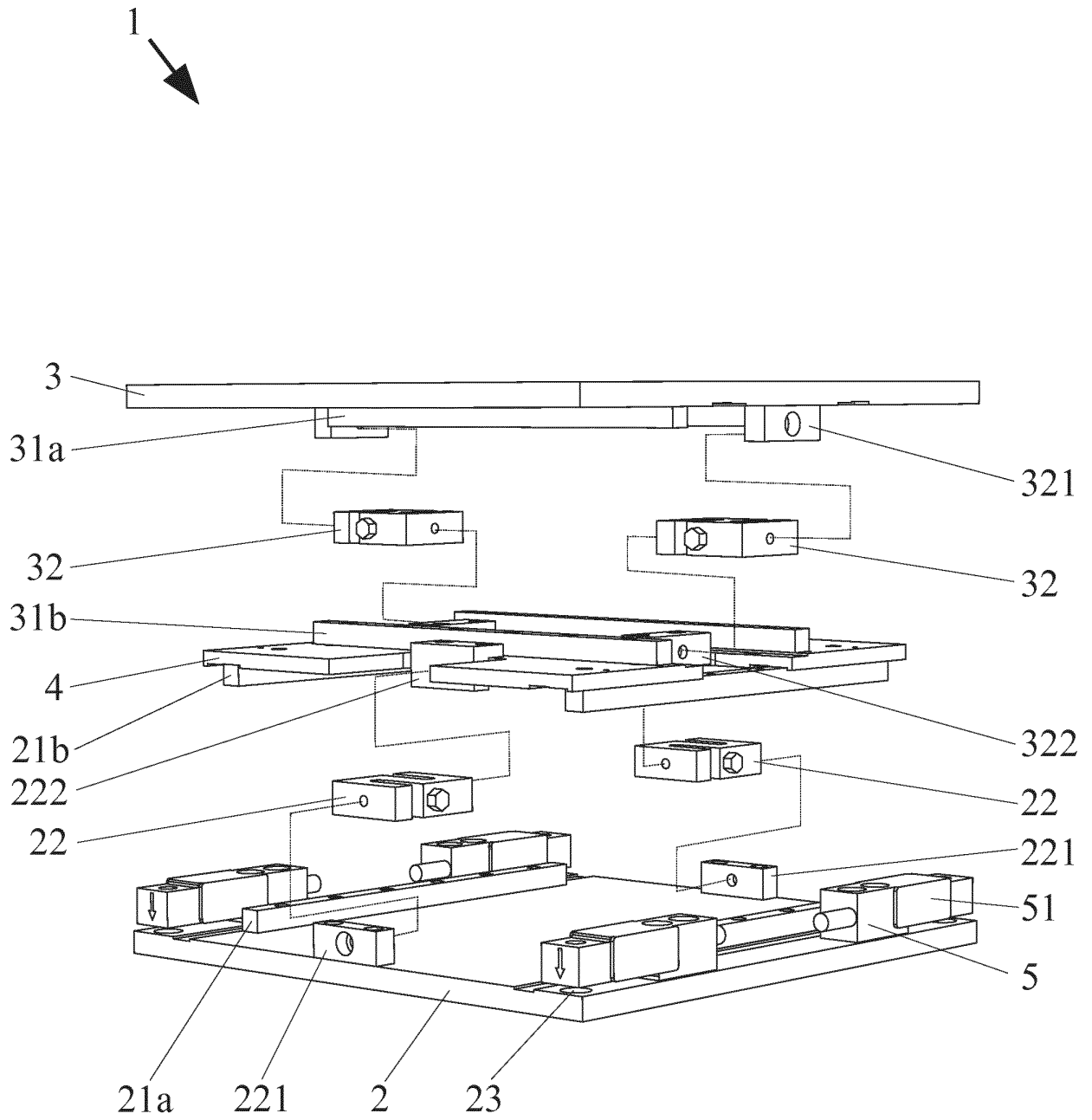

FIG. 2

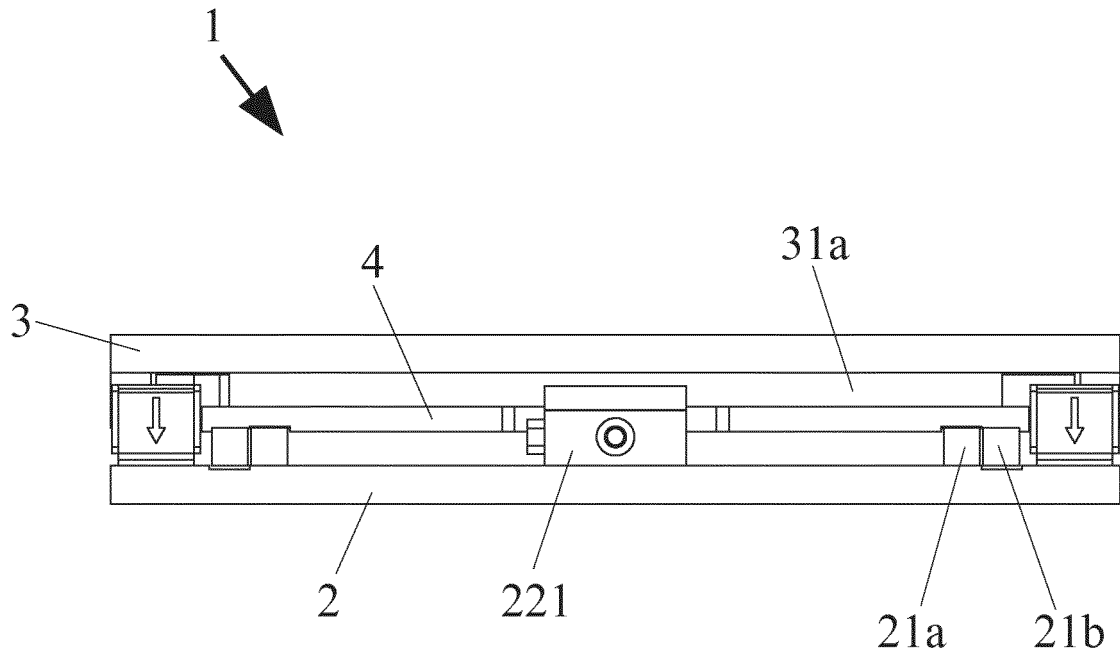

FIG. 3

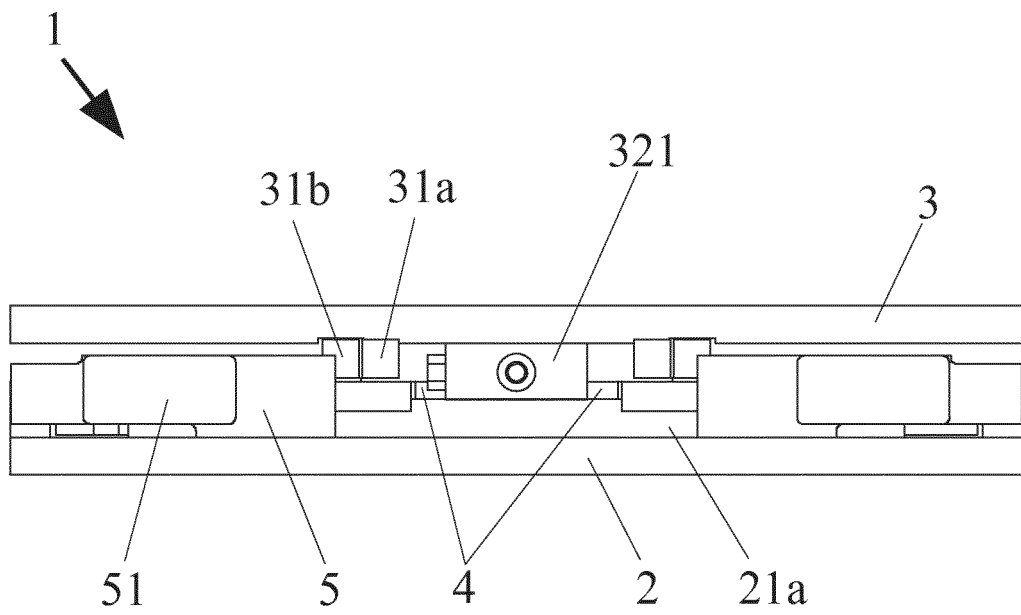

FIG. 4

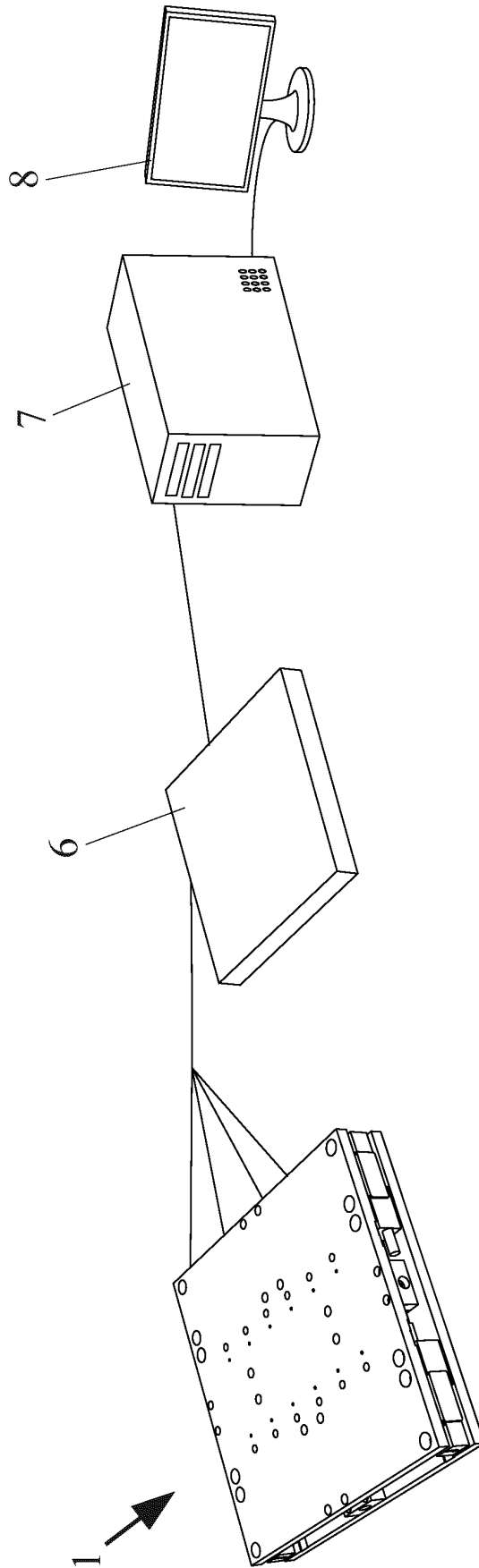

FIG. 5

REFERENCES CITED IN THE DESCRIPTION

This list of references cited by the applicant is for the reader's convenience only. It does not form part of the European patent document. Even though great care has been taken in compiling the references, errors or omissions cannot be excluded and the EPO disclaims all liability in this regard.

Patent documents cited in the description

- CN 2015088390 W [0001]
- TW M404973 [0006]
- WO 2006075941 A [0006]